

## Operating instruction english

Revision	C
Date	02.03.2015
Issuer	NH

This operating instruction is not  
subject to the updating

## Self sealing coupling

1-07-003-0-.....-...-

1-07-003-2-.....-...-

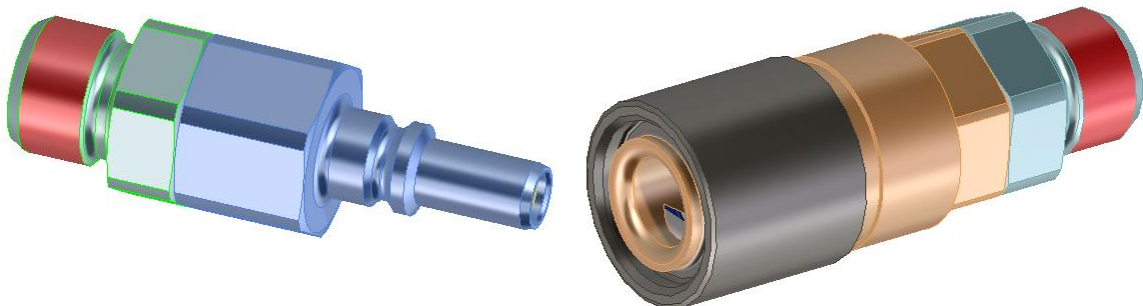

This coupling is a quality product, in which special attention has been paid to high functionality, ease of operation, safety and reliability. As an item of technical equipment this coupling is intended for use in the commercial, industrial area and for operators, who have been trained by specialists in the handling of technical systems / tools.

**Customer care:**

As part of our individual customer care we will be happy to assist you in questions relating to use and operation and on any problems encountered.

**Service and maintenance:**

In order to maintain the high technical performance capability and reliability of your coupling over many years, we recommend regular inspection and maintenance.

We can thereby offer you optimum support by our Customer Service department and the conclusion of a service and maintenance contract. Please ask for a quotation.

WALTHER-PRÄZISION  
Carl Kurt Walther GmbH & Co. KG  
Westfalenstraße 2  
42781 Haan

PO Box 42 04 44  
42404 Haan  
Germany

telephone: +49 (0) 2129 / 567-0  
telefax: +49 (0) 2129 / 567-450

E-Mail: [info@walther-precision.de](mailto:info@walther-precision.de)  
Internet: [www.walther-precision.de](http://www.walther-precision.de)

**Contact:**

Application technology and service

Holger R. Figge

telephone: +49 (0) 2129 / 567-591  
telefax: +49 (0) 2129 / 567-590  
mobile: +49 (0) 162 / 2090100  
e-mail: [hfigge@walther-precision.de](mailto:hfigge@walther-precision.de)

Further addresses and telephone numbers of contacts can be found on the Internet on our homepage under [http://www.walther-precision.de/english/info\\_kontakt/service](http://www.walther-precision.de/english/info_kontakt/service).

## List of Contents

### 1 List of Contents

<b>1</b>	<b>LIST OF CONTENTS .....</b>	<b>3</b>
<b>2</b>	<b>GENERAL.....</b>	<b>4</b>
<b>3</b>	<b>WARRANTY.....</b>	<b>5</b>
3.1	GENERAL .....	5
3.2	REPLACEMENT PARTS .....	5
<b>4</b>	<b>SAFETY INSTRUCTIONS .....</b>	<b>6</b>
<b>5</b>	<b>PRODUCT DESCRIPTION OF THE SELF SEALING COUPLING .....</b>	<b>7</b>
5.1	INTENDED USE .....	7
5.2	TECHNICAL DATA .....	7
<b>6</b>	<b>INSTALLATION INSTRUCTION .....</b>	<b>8</b>
<b>7</b>	<b>OPERATING INSTRUCTION .....</b>	<b>9</b>
7.1	CONNECTION PROCESS.....	9
7.2	DISCONNECTION PROCESS .....	9
<b>8</b>	<b>MAINTENANCE INSTRUCTION.....</b>	<b>10</b>
8.1	MAINTENANCE: .....	10
8.2	FUNCTIONAL TESTING: .....	11
<b>9</b>	<b>TEST .....</b>	<b>12</b>
9.1	IMMERSION TEST .....	12
9.1.1	<i>Test setup of the connected state (schematic view) .....</i>	<i>12</i>
9.1.2	<i>Test procedure.....</i>	<i>12</i>
9.1.3	<i>Test disconnected.....</i>	<i>13</i>
9.1.4	<i>Test setup of the disconnected state (schematic view) .....</i>	<i>13</i>
9.1.5	<i>Test procedure.....</i>	<i>13</i>
9.1.6	<i>Test result .....</i>	<i>13</i>
9.2	PRESSURE TEST.....	14
9.2.1	<i>Test setup of connected state (schematic view).....</i>	<i>14</i>
9.2.2	<i>Test procedure.....</i>	<i>14</i>
9.2.3	<i>Test disconnected.....</i>	<i>15</i>
9.2.4	<i>Test setup of the disconnected state (schematic view) .....</i>	<i>15</i>
9.2.5	<i>Test procedure.....</i>	<i>15</i>
9.2.6	<i>Test result .....</i>	<i>16</i>
9.3	DOCUMENTATION .....	16
<b>10</b>	<b>LUBRICATION !.....</b>	<b>17</b>
<b>11</b>	<b>STORAGE .....</b>	<b>17</b>
<b>12</b>	<b>SHUT-DOWN.....</b>	<b>17</b>
<b>13</b>	<b>INDEX.....</b>	<b>18</b>

## 2 General

This operating instruction contains all regulations for operation, commissioning and maintenance of the coupling.

All information and notes in this operating instruction were collated while taking into consideration the valid regulations, the current engineering related status of development as well as our many years of experience and acquired knowledge.

Translations of this operating instruction were also produced according to the best of knowledge. However, we cannot assume liability for any translation errors. The German version provided for this operating instruction is considered the authoritative version.

The actual scope of delivery can deviate from the explanations and graphic representations described herein under certain circumstances, e.g. in the case of special designs, utilization of additional order options or because of state-of-the-art technical alterations. If you have any questions, please contact WALTHER-PRÄZISION.



This operating instruction must be read carefully before starting work on or with the equipment, in particular before commissioning! WALTHER-PRÄZISION assumes no liability for damage or faults arising from non-compliance with the instructions in this operating instruction.

The operating instruction must be kept directly with the equipment and be accessible to all persons who work on or with the equipment.

It is not permitted for the operating instruction to be passed to third parties and if applicable this will incur damage compensation. All other rights reserved.

Before commissioning the device must be checked for being not defective and its technically perfect function.

The German version is the original.

We reserve the right to make technical alterations to the product within the context of improving the usage properties and further development.

The operating instruction remains our property.

Any reproduction, use by or communication to third parties incurs a penalty and will be pursued by court action (copyright law against unfair competition, BGB [German Civil Code]). All rights reserved in the case of a patent award (Paragraph 7, Section. 1 of the patent law - PG) or entry as a patented design (Paragraph 5, Section 4 of the patented design law - GMG).

### 3 Warranty

#### 3.1 General

The warranty is in accordance with:

The regulations agreed upon in the purchase contract and

The "General terms and conditions for delivery and service" of WALTHER-PRÄZISION using the version valid at the time the purchase contract came into force.

Generally excluded from the warranty are consumables.

Typical consumables in products from WALTHER-PRÄZISION are, for example:

- Seals
- Springs
- Electro plug contacts
- Electrical cables and hoses which are subject to regular alternating bending or torsional stresses.

Components that are not normally subject to wear under the conditions to be expected (environmental and usage) may become consumables if the described product is not operated according to the intended purpose or is operated with a disregard for the specifications in the operating instructions.

For example, electrical cables with sheathing that has been destroyed by extreme exposure to welding sparks would not fall under the warranty.

In addition, wear to other components caused by unusual environmental conditions, not expressly coordinated with WALTHER-PRÄZISION, for example, high temperatures, dusts with an abrasive effect, high humidity or corrosive vapours and gases are not covered by the warranty.

Cycle, time or load dependant specifications for the replacement of certain components of the described product within the framework of maintenance are not warranty-relevant durability statements, they are instead recommendations designed as preventive maintenance to avoid standstill times during production.

#### 3.2 Replacement parts

##### Warning!

**The use of non-Walther-parts can cause personal injuries, death as well as material damage.**

Only original parts from WALTHER-PRÄZISION are to be used.  
These are to be installed according to their intended purpose.

When using third-party items or parts that have not been approved by WALTHER-PRÄZISION, all warranties, guarantees and service claims are voided without notification.

## Safety instructions

---

### 4 Safety instructions

Using these operating instruction does not release the customer from his obligation to comply with the pertinent work safety regulations e.g. operational safety regulations, etc. The duty to take due care by the operator of the couplings includes planning measures to ensure proper operation and monitoring their implementation.



#### Hazard notes

If the wrong product has been selected or if there is improper use or maintenance has been omitted, then hazards arise and personal injuries and material damage can occur from:

- hazardous emission of fluid or individual particles/coupling parts.
- function impairments of connected systems or tools.
- The metal parts of coupling and adaptor are not thermally protected. You can be burned if you touch these parts at high media temperatures. According to the ambient temperature valve lever and ring grip can also become unbearably hot. For that reason suitable, sufficiently long protective gloves should be worn.



#### The operator must in particular make sure that

- the materials, designs and seals which were used in the coupling halves were selected by in a responsible manner of customer designers, purchasers or operators by themselves for their medium, pressure and flow combinations.
- the couplings are only used according to the intended purpose.
- the couplings are only operated in a perfect, functioning condition.
- the operating instruction is always in a legible condition and is available in its entirety to operating personnel.
- the operating personnel are sufficiently acquainted with the working method and the safety notes for the coupling.
- no safety devices must be removed and/or deactivated during operation of the couplings.
- before installing or dismantling the couplings, you have made sure that the couplings have not been pressurized.



#### After completing assembly and installation work and before commissioning the coupling, the following items have to be observed:

Check once again that all screw connections are securely fitted.

Before commissioning the couplings, a function test must be carried out (see maintenance and function test).

## Product description of the self sealing coupling

### 5 Product description of the self sealing coupling

Coupling connection consists of:

- self sealing coupling 1-07-003-0-.....-..-
- self sealing adaptor 1-07-003-2-.....-..-

In case that both coupling halves are not connected they should be protected against external dirt and/or damages if required.

For that purpose dust cap and dust plug are available. Possible combinations :

- |                       |                 |
|-----------------------|-----------------|
| self sealing coupling | 1-07-003-0 with |
| dust plug             | 1-07-003-6      |
| self sealing adaptor  | 1-07-003-2 with |
| dust cap              | 1-07-003-5      |

#### 5.1 Intended use

- The coupling shall only be used to connect two lines.
- The coupling- and decoupling process is manually operated.
- The coupling is equipped with an automatic lock, i. e.:

##### **one-hand operation**

- The coupling is especially suitable for the following media / applications, provided the correct coupling material as well as sealing material were chosen
  - air, -water, -hydraulic oil
  - and their subspecies (such as oxygen or oil with additives)
- **Regarding any other purposes of use you should contact WALTHER-PRÄZISION.**

#### 5.2 Technical data

##### **CAUTION**

**For normed threaded connections, when specifying the operating pressure, the highest permitted operating pressure of the connection must be taken into account!**

**Differing higher or lower operating pressures are possible according to material characteristics or the connection. This operating pressure is to be taken from the project-specific documentation.**

**operating pressure maximum:** 200 bar (brass, stainless steel)

**Cv-value:** 0.14

##### **Temperature**

The permissible working temperature ranges usually between +5 °C and +70 °C.  
Deviating working temperatures are listed separately for specific projects.

- The coupling is not determined for any types of use and technical values other than those listed here.
- Safe operation is not guaranteed if the coupling is used contrary to its intended use and technical values
- The operator of the coupling is responsible for all personal injuries or material damage that occur from non-intended use and disregard of the technical values; the manufacturer assumes no responsibility in these cases.

## Installation instruction

### 6 Installation Instruction

Install the self sealing coupling into the network in due consideration of the general accident prevention regulations, so that:

- an error-free operation according to the operating instructions is guaranteed. Please make sure that you use only the hexagon on the connection which is provided by the customer to tighten or release the coupling / adaptor when assembling or dismantling it (see picture).

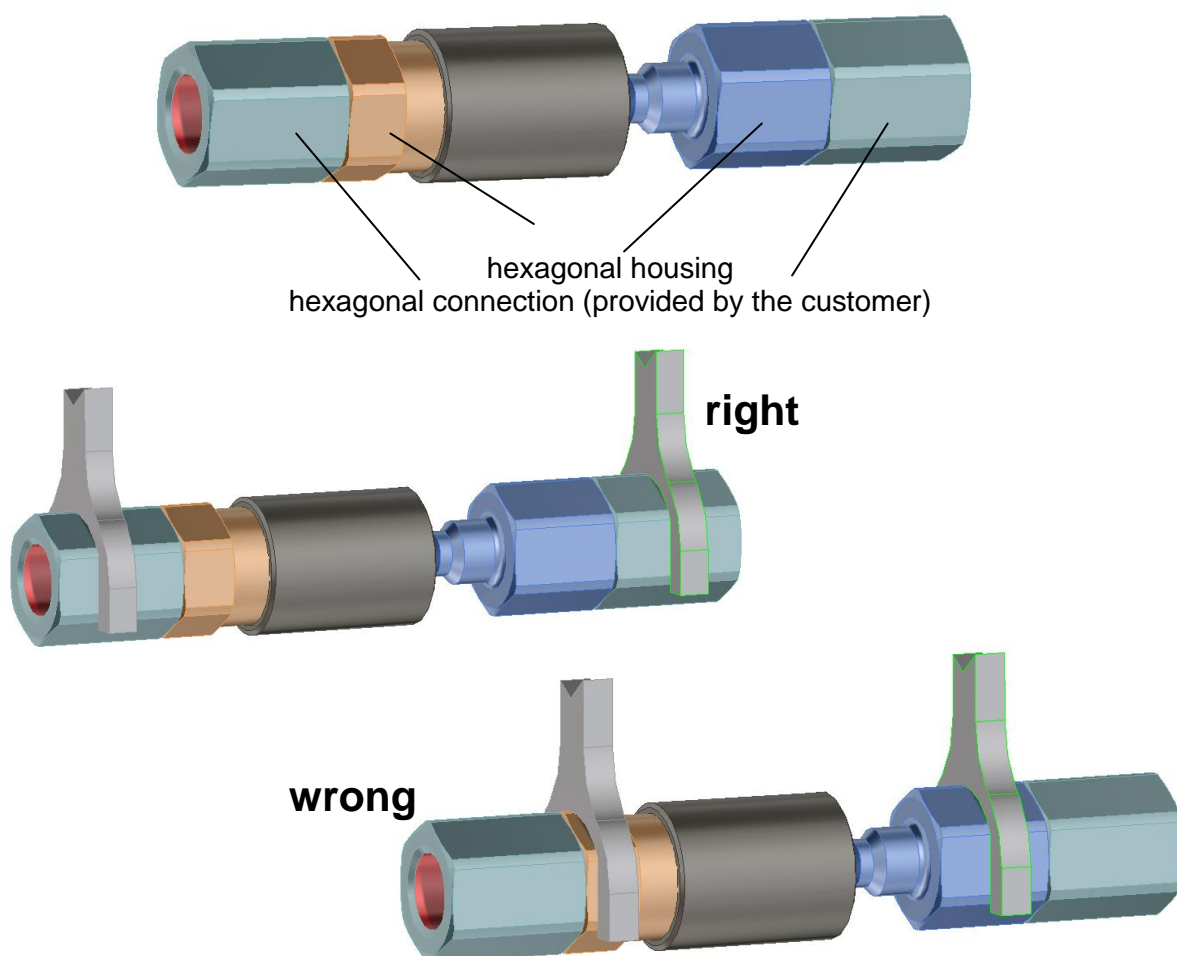

- the screw connection on the connection side (provided by the customer) is made according to the relevant technical regulations.
- the self sealing coupling is predominantly used on the network side and the self sealing coupling is mainly used on the consumer side.
- exterior damage to the unit and to all movable parts is ruled out.

Before installing the through type coupling and the adaptor to the piping system, make sure that the piping system has been sufficiently flushed/blown or cleaned.



**After completing the installation work, perform a function test both depressurised and under working pressure, as described in the operating instructions.**



## Operating instruction

---

### 7 Operating Instruction

In order to avoid critical injuries of the staff and damage at the self sealing coupling during operation, coupling may be only used for the stated applications.

#### 7.1 Connection process

Before each coupling process a visible check of the coupling and the adaptor has to be made. Damaged parts must be changed in case of observable, visible damages or deformations.

The self-sealing coupling is equipped with an automatic lock, i. e. one-hand operation. For coupling the self-sealing coupling behind the locking sleeve or the self-sealing adaptor in the end plug area is taken up with one hand and pushed axially centred on the counter piece until the end stop.

During the coupling the locking sleeve snaps in forward without the aid of the operator.

Now the self-sealing coupling and the self-sealing adaptor are locked mechanically. Available valves are opened during the coupling process and thus the passage is released.



#### **CAUTION**

Please take care that locking sleeve is in final position, i.e. that it is flush in front with the coupling housing as otherwise no perfect lock is guaranteed.

#### 7.2 Disconnection process

For decoupling the self-sealing coupling behind the locking sleeve is taken up with one hand, with the other hand the locking sleeve is pulled back and the connection is separated.

During the decoupling the available valves close automatically so that no further discharge of media is possible.

#### **Caution!**

In case of an available pressure in the line connected by the coupling system a strong separation impulse - depending on the pressure - can be effective onto the coupling system during disconnection. For that reason the movable part of the coupling (free half) is to be firmly held in the hand to avoid injuries.

## Maintenance and Functional instruction

---

### **8 Maintenance Instruction**

The WALTHER – coupling units are to be handled in such a way exterior damage to the elements as well as to all moving parts is prevented.

In order to minimise activation forces and to extend the lifetime of the coupling unit, we recommend lightly lubricating the connecting surfaces if this is permitted (see lubrication instructions).

In order to always ensure the functionality of the coupling unit and thus the protection of the operator, maintenance and functional testing must be carried out independantly of the operating instructions and at a suitable interval.

#### **Note!**

**In the event of maintenance that is carried out by neither WALTHER-PRÄZISION nor by personnel trained by WALTHER-PRÄZISION, the warranty of WALTHER-PRÄZISION is voided. This does not apply when maintenance is carried out by personnel trained by WALTHER-PRÄZISION.**

#### **Note!**

**In the event of media that is hazardous to health a coupling unit returned to WALTHER-PRÄZISION must be sent in a fully cleaned state. No media hazardous to health may be released from the coupling unit during the dismantling process. The sending party (customer) is responsible for this.**

#### **8.1 Maintenance:**

- With the coupling unit in the decoupled state, carry out an external visual check for damages and contamination.
- Contamination in the functional area that can be accessed from the outside (seal region, activation elements) must be removed by wiping.

In the event of damaged, cracked or corroded parts, the coupling unit must be removed and sent to WALTHER-PRÄZISION for repair (see Note).

In the event of worn, brittle or overaged seals as well as serious contamination, it is the decision of the customer whether they wish to send the coupling unit WALTHER-PRÄZISION or whether they wish to repair it themselves (see Note).

## Maintenance and Functional instruction

---

### 8.2 Functional testing:

As described in the operating instructions, the coupling unit is coupled, pressure is applied and it is decoupled and this process is carried out multiple times.

In doing so, the following should be taken into consideration:

- Proper, easy functionality when coupling and decoupling.
- Sealing of the coupling unit in the coupled and decoupled state.

In the event of damaged, cracked or corroded parts, the coupling unit must be removed and sent to WALTHER-PRÄZISION for repair (see Note).

In the event of worn, brittle or overaged seals as well as serious contamination, it is the decision of the customer whether they wish to send the coupling unit to WALTHER-PRÄZISION or whether they wish to repair it themselves (see Note).

### Note!

**When repairing, a pressure and sealing test must always be carried out.  
This may also be completed by means of the working process.  
The procedure and scope of this test is described in the "Test" section.**

## 9 Test

For applications up to 2 bar, WALTHER-PRÄZISION recommends a leakage test by immersion trial. For applications above 2 bar, it is up to the user, if a leakage test by immersion trial or a pressure test by test bench has to take place.

### 9.1 Immersion test

#### 9.1.1 Test setup of the connected state (schematic view)

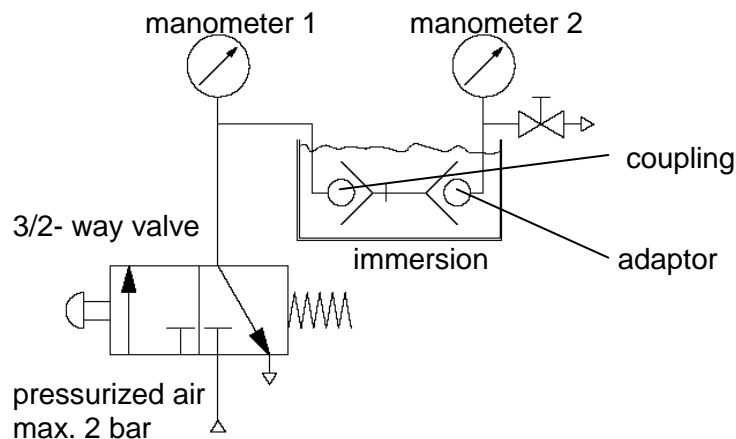

#### 9.1.2 Test procedure

- Prepare test setup
- 3/2-way valve is operated by sensing device and held up during the test.
- Valve is impinged with max. 2 bar pressurized air, both manometers show the same existing pressure.
- The holding time of the test is 10 seconds.
- To stop testing, release the sensing device at the 3/2-way valve. Through the preload, the 3/2-way valve runs back to the starting position.
- The medium in the test setup (pressurized air) escapes through the 3/2-way valve. Both manometers must show **0 bar** now.

### Attention

**If this does not happen, the test is not carried out correctly.  
It is not allowed to disconnect now.**

- By opening the stopcock at manometer 2, the remaining pressure can be reduced now.
- As soon as both manometers show 0 bar, disconnecting and dismantling of the test setup is permitted.
- After successful failure detection and elimination, the test has to be repeated correctly.
- After the test, the valve has to be dried as soon as possible in warm air (recommendation: 45 – 55 °C, approx. 30 min. in air stream, up to 2 hours in stagnant air, depending on the device).

### 9.1.3 Test disconnected

Test setup and procedure are identical for both coupling and adaptor.

### 9.1.4 Test setup of the disconnected state (schematic view)

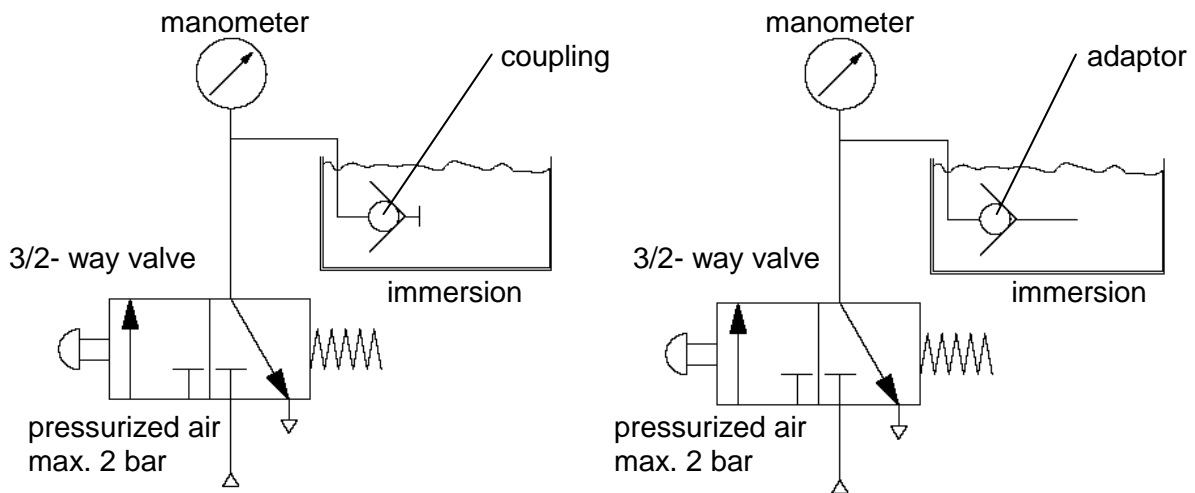

### 9.1.5 Test procedure

- Prepare test setup
- 3/2-way valve is operated by sensing device and held up during the test.
- Valve is impinged with max. 2 bar pressurized air, both manometers show the same existing pressure.
- The holding time of the test is 10 seconds.
- To stop testing, release the sensing device at the 3/2-way valve. Through the preload, the 3/2-way valve runs back to the starting position.
- The medium in the test setup (pressurized air) escapes through the 3/2-way valve. After correct test setup, the manometer will show **0 bar** again.
- Dismantling of the test setup is permitted now.
- After the test, the valve has to be dried as soon as possible in warm air (recommendation: 45 – 55 °C, approx. 30 min. in air stream, up to 2 hours in stagnant air, depending on the device).

### 9.1.6 Test result

During the holding time of 10 seconds, bubbling shall not occur neither in connected, nor in disconnected state. If bubbling occurs in these 10 seconds, the valve has to be considered leaking and is not permitted for use. Failure detection and elimination has to be carried out as well as a new test.

## 9.2 Pressure test

### 9.2.1 Test setup of connected state (schematic view)

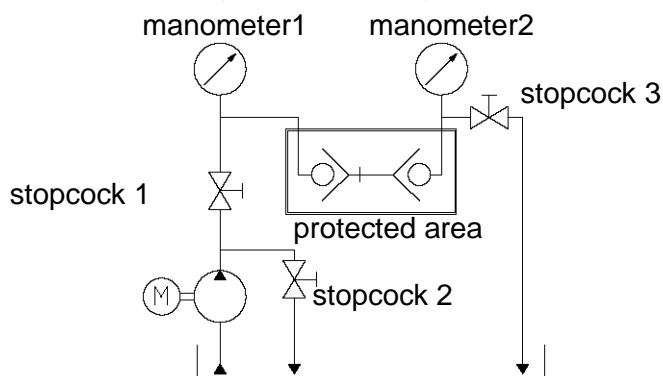

### 9.2.2 Test procedure

- Prepare test setup.
- The test setup must be laid out in accordance to relevant safety regulations, e. g. industrial safety regulations etc. and to the required pressure. The container (protected area) in which the valve is laid during the test, must be laid out so that neither escaping media under pressure nor parts of the test piece can endanger the operator (e. g. bursting).
- Test media is water or oil, according to the material of the valve which has to be tested. The sealing material EPDM shall not be tested with oil.
- The user of the test setup is required to plan and control the implementation of appropriate measures to ensure a safe operation.
- At the beginning of the test, stopcock 1 is open, stopcocks 2 and 3 are closed.
- Before the pressure test, it has to be ensured that no gaseous/compressed media is left in the valve.
- For this purpose, the valve has to be vented before pressurization. Open stopcocks 1 and 3 and lead the test media through the test piece until there is no more gaseous media left.
- Switch off pump and close stopcock 3.
- Slowly apply pressure to the valve. Pressure test is 1,3 x working pressure. (working pressure, please see product description).
- Both manometers show test pressure.
- Close stopcock 1; test pressure is locked within the valve for 5 min.
- Switch off pump and open stopcock 2.
- To finish testing, open stopcock 1 and the test media will flow back into the container.
- Both manometers must show **0 bar** now.

#### Attention

**If this is not happened, the test is not carried out correctly.**

**Disconnecting is not permitted now.**

- By opening stopcock 3, the residual pressure can escape.
- If both manometers show 0 bar, disconnecting and dismantling of the test setup is permitted.

- After successful failure detection and elimination, the test has to be repeated correctly.
- After the test, the valve has to be dried as soon as possible in warm air (recommendation: 45 – 55 °C, approx. 30 min. in air stream, up to 2 hours in stagnant air, depending on the device).

### 9.2.3 Test disconnected

Test setup and test procedure are identical for both coupling and adaptor.

### 9.2.4 Test setup of the disconnected state (schematic view)

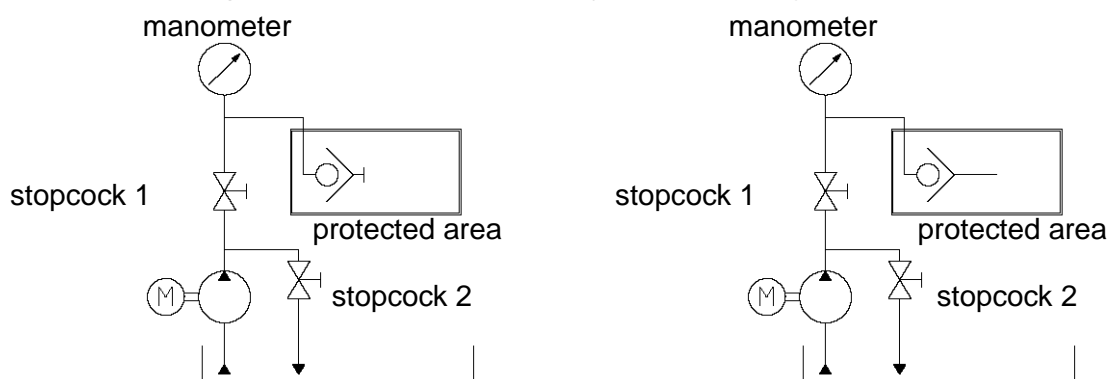

### 9.2.5 Test procedure

- Prepare test setup.
- The test setup must be laid out in accordance to relevant safety regulations, e. g. industrial safety regulations etc. and to the required pressure. The container (protected area) in which the valve is laid during the test, must be laid out so that neither escaping media under pressure nor parts of the test piece can endanger the operator (e. g. bursting).
- Test media is water or oil, according to the material of the valve which has to be tested. The sealing material EPDM shall not be tested with oil.
- The user of the test setup is required to plan and control the implementation of appropriate measures to ensure a safe operation.
- Before the pressure test, it has to be ensured that no gaseous/compressed media is left in the valve.
- For this purpose, the valve has to be vented before pressurization. This is only possible in coupled state. Open Stopcocks 1 and 3 (see test in coupled state) and lead test media through test piece until there is no more gaseous media left.
- Switch off the pump, disconnect the unit and slowly pressurize the respective side (coupling or adaptor). Test pressure is 1,3 x working pressure (working pressure see product description).
- Manometer shows test pressure.
- Close stopcock 1; test pressure is locked within the valve for 5 min.
- Switch off pump and open stopcock 2.

- To finish testing, open stopcock 1 and the test media will flow back into the container. The manometer must show **0 bar** after correct test setup.
- The test setup can be dismantled.
- After the test, the valve has to be dried as soon as possible in warm air (recommendation: 45 – 55 °C, approx. 30 min. in air stream, up to 2 hours in stagnant air, depending on the device).

#### 9.2.6 Test result

After 5 min. of testing, the pressure decrease must not exceed 5 % in connected and disconnected state with a test pressure up to 700 bar.

With a test pressure of more than 700 bar, the pressure decrease must not exceed 3 %. If the pressure loss is higher or if media escapes obviously, the valve is to be considered leaking and is not permitted for use.

Failure detection and elimination as well as a new test are required.

#### 9.3 Documentation

Tests have to be documented with registration of test pressure, test media, name/date and signature.



## **10 Lubrication !**

In order to minimize the activation forces and to extend the lifetime of the coupling, we recommend cleaning and lightly greasing the connecting surfaces at suitable intervals as long as there is no risk that contamination in the vicinity will cause increased wear in combination with grease.

Lubrication is not carried out if the application does not permit it (e.g. in medical technology).

The selection of the lubrication is determined by the operator of the coupling and their purchasing options.

The connecting surfaces may only be lubricated if the operating conditions permit it.

Thus:

- The lubrication must be selected in accordance with compatibility with the seal quality and material.
- Media/lubrication combinations in which the lubrication properties are changed (e.g. turns to resin) must be avoided.
- Media/lubrication combinations that prevent safe operating conditions (e.g. lubrication/oxygen) must be avoided.

The lubrication interval depends on the framework conditions and the use of the application and is determined by the operator.

## **11 Storage**

The coupling must be stored in a way that it cannot be damaged.

To avoid damage or dirt the transportation covers must be attached on all connections.

The storage conditions of the coupling depend on the guidelines applicable to the gaskets, since improper storage can lead to deterioration of the gaskets.

The following points must be observed:

- The gaskets must be stored dry.
- For the preservation of the gaskets, the gaskets should not be stored where they are exposed to the effects of daylight.
- For protection against oxygen, the gaskets should be stored in the original packaging.

## **12 Shut-down**

At the end of the service life the coupling or its components have to be disposed non-polluting and according to the legal regulations.

For that the local public or private disposal societies should be taken.

## 13 Index

### A

According to intended purpose.....	6
Activation forces.....	17
Adaptorl.....	6
air.....	7
Applications.....	7
Assembly.....	6

### C

Commissioning.....	4, 6
connected.....	7
connection.....	7
Connection process.....	9
Consumables.....	5
Contact.....	2
coupling.....	4, 6
Coupling.....	6, 7, 17
Customer care, individual.....	2
Cv-value.....	7

### D

Damage.....	6
Damage compensation.....	4
Disconnection process.....	9
Dismantling.....	6
Disposal societies.....	17
Disregard.....	7
dust cap.....	7
dust plug.....	7

### E

Environmental conditions.....	5
-------------------------------	---

### F

Fluid.....	6
Fully cleaned state.....	10
Function.....	6
Function test.....	6

### G

General.....	4
General terms and conditions for delivery and service.....	5
Guarantees, void without notification.....	5
Guidelines applicable to the gaskets.....	17

### H

Hazard notes.....	6
Hazardous emission.....	6
hydraulic oil.....	7

### I

Implementation.....	6
Improving.....	4
Index.....	18
Installation Instruction.....	8
Intended use.....	7

### K

kontrollieren.....	14, 15
--------------------	--------

### L

Legible condition.....	6
Liability.....	4
Lifetime.....	10, 17
List of Contents.....	3
Lubrication in accordance with compatibility with the seal quality.....	17

### M

Maintenance.....	4, 6
Maintenance Instruction.....	10
Media temperatures.....	6
Media that is hazardous to health.....	10

### N

No liability.....	4
-------------------	---

### O

one-hand operation.....	7, 9
Operated, not according to the intended purpose.....	5
Operated, with a disregard for the specifications.....	5
Operating Instruction.....	9
operating pressure maximum.....	7
Operational safety regulations.....	6
operator.....	6
Original parts.....	5

### P

Parts, damaged.....	10, 11
---------------------	--------

Perfect, functioning condition.....	6	subspecies .....	7
personnel trained by Walther-Präzision .....	10	Systems .....	6
pressurized .....	6	<i>T</i>	
Product description .....	7	Technical data .....	7
Protective gloves .....	6	Technical values .....	7
Purchase contract.....	5	Temperature .....	7
<i>R</i>		Thermally .....	6
Regulations .....	4	Third-party items.....	5
responsible .....	7	Tools .....	6
Responsibility .....	10	Translation errors.....	4
<i>S</i>		Transportation covers .....	17
Safety devices.....	6	Types of use .....	7
Safety instructions.....	6	<i>V</i>	
Scope of delivery, actual .....	4	Visual check.....	10
Screw connections.....	6	<i>W</i>	
Seal .....	10, 11	Warranty, void without notification .....	5
Sealing test .....	11	Warranty, excluded from .....	5
self sealing adaptor .....	7	water .....	7
self sealing coupling .....	7, 9	Work safety regulations .....	6
Service and maintenance contract.....	2	Working method .....	6
Service claims, void without notification .....	5	Wrong product selection .....	6
Shut-down .....	17		
Storage .....	17		
Storage conditions.....	17		